

CentOS is not Dead

The Fedora, CentOS and RHEL pipeline
Understanding how stable, enterprise focused software is created

By Peter Larsen
Red Hat

May 27th, 2021



I'll rather be here ...



Shameless self promotion

- Danish born, raised and lived in Denmark until 1998. Now US Citizen.
- I'm a programmer, system admin, database admin, network admin, storage admin, container person, security enforcer – jack of all trades
- Helps with several LUGs - speaking, arranging speakers, finding space etc
- Used Linux since kernel 0.99b – around 1994
- Works for Red Hat – the largest Enterprise Open Source/Linux company in the world (now part of IBM)
- Talks at Linux User Groups, large enterprise conferences about “Linux”, containers, programming and related technologies
- Love spending time with grandkids, drones, MCU programming and electronics



@egoalter



peter@peterlarsen.org

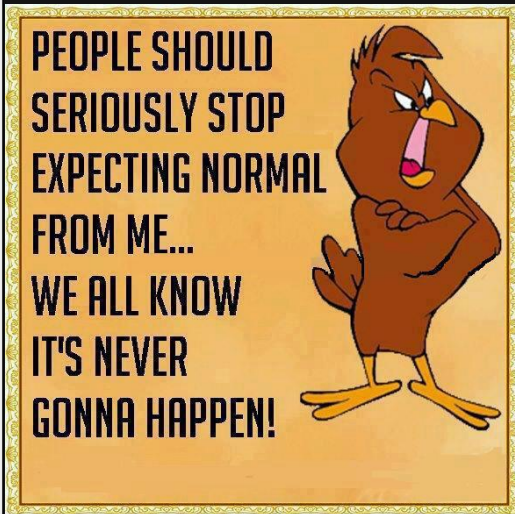

Why listen to me about CentOS?

- Not my first rodeo - was invited to do so
- Not part of the CentOS board - just a normal user
- I've used a lot of CentOS over the years
 - But lately not so much - less than a handful of CentOS now
 - Most of what I do is made to use RHEL only
- Used Red Hat Linux when it was around
- Used Fedora since FC6

- I am a Red Hatter - I work with people who are involved with the CentOS project who have helped me with some of the content I am presenting
- Been part of, participated in, open source communities since the world of BBSes and FidoNet
- Linux has been my work platform the last ~25 years



FUCK IT

I'm going home.

Open Source Guy

- It's what I do
- It's what I promote
- It's how I work
- It's how I try to live

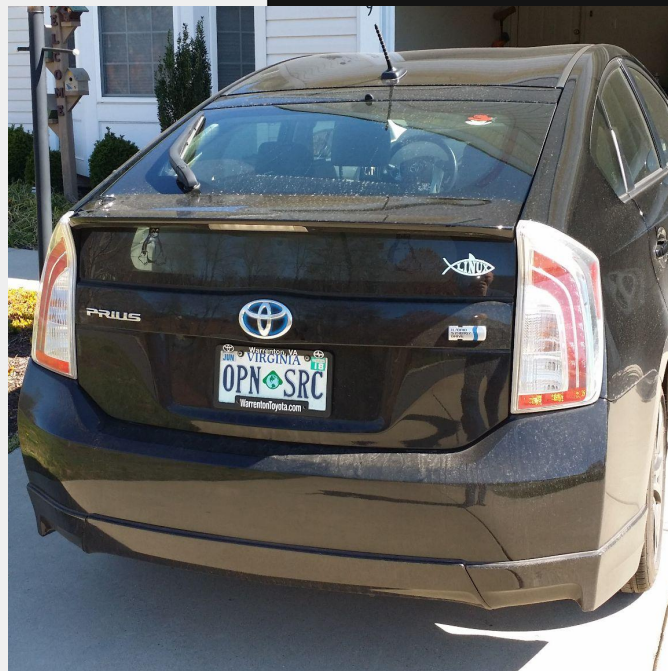

Any software developers in the house?

Warning

- We will be talking a little bit about software development
 - **Git:** Source repository
 - **Builds:** Process of turning source into executables that can be installed
 - **Patches/PR:** Change instructions to code
 - **Issue tracking/Bugzilla:** Reporting of issues and developer type talks
- We'll be talking about how the CentOS sausage is made

|

Survey

- Who are existing CentOS users?
- Who's considering changing “because CentOS is going away”?

Well DON'T because it's not going away!

Red Hat's December 8th



Hilary 🧟 BisenEEKs 🇺🇸 🍪 🌶️ 🦅 🦄 🐰
@HBBisenieks



so in the last 24 hours, we find out that FireEye was hacked and that CentOS 8 is being killed (probably by IBM, who bought RedHat, who took ownership of CentOS, last year) in a year. that's eight years early.

5:23 PM · Dec 9, 2020

♡ 👤 See Hilary 🧟 BisenEEKs 🇺🇸 🍪 🌶️ 🦅 🦄 🐰's other Tweets



Silvio Balduzzi
@balduz84



I hate the #RedHat plan for #CentOS. I have worked great with CentOS but am not available for the beta testing role now. My machines need stability, even though they are not production.

11:47 AM · Jan 3, 2021



♡ 👤 See Silvio Balduzzi's other Tweets



Thorsten Heller
@ThoHeller



With #CentOSStream, #RedHat Just Killed #CentOS as we Know it buff.ly/3a3t1X4 by @itsfoss2



IBM's Red Hat Just Killed CentOS as we Know it: With CentOS Stream, St...
CentOS is regarded as a stable, secure and free Linux server distribution. The stability part is being jeopardized thanks to the latest changes to the...
itsfoss.com

1:53 PM · Dec 9, 2020



♡ 👤 See Thorsten Heller's other Tweets

What changed - the details

- <https://wiki.centos.org/FAQ/CentOSStream>
- <https://www.redhat.com/en/blog/faq-centos-stream-updates>
 - CentOS Linux → CentOS Stream
 - CentOS Linux 8 retires as of 12/31 2021
 - CentOS Stream 8 already exists - so CentOS 8 continues
 - CentOS Stream 9 will “soon” be announced and become a vital part of the build pipeline of RHEL9
 - Initial release just made late last week - very early “pre-baked” version
 - CentOS Linux 7 will continue until June 30th 2024

- TL;DR version:

Red Hat decided to move CentOS into an upstream position providing better access for system integrators and contributors. Instead of being behind RHEL it will now be slightly in front. No more dot releases - and CentOS8 Linux (the current CentOS) will stop as of December 31st 2021.

The rumors of my death



Community vs. Reality



Reality

CentOS is alive and no funeral is planned

- CentOS Stream is not a rolling release
- CentOS Stream is closer to RHEL than CentOS Linux was/is.
- The “change” users need to do is very basic:
 - `# dnf swap centos-linux-repos \`
`centos-stream-repos`
 - `# dnf distro-sync`
- CentOS can now be a real FOSS community

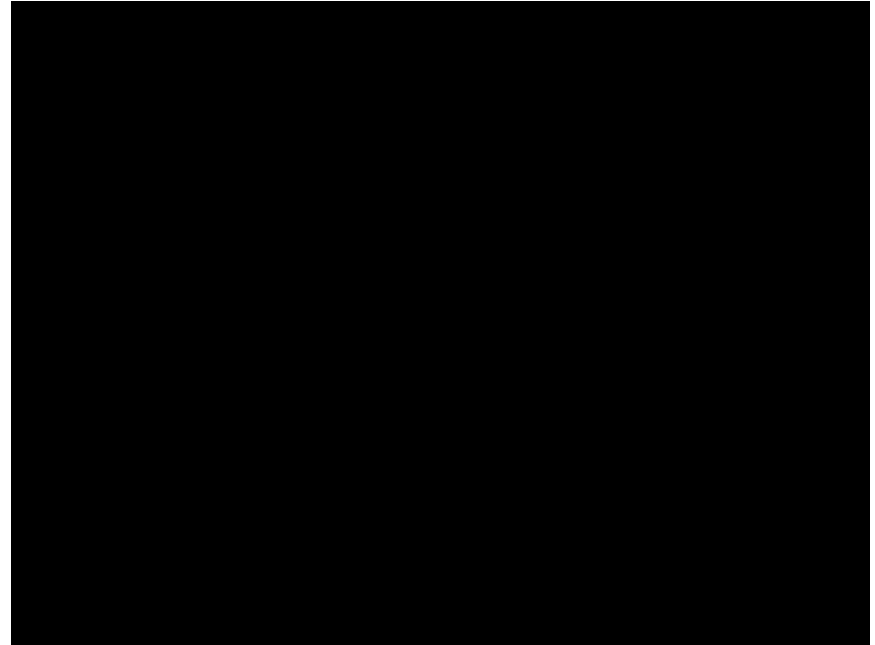

FOSS

- Free Open Source Software
- Is not free as in no cost
- Free as in liberty is what GPL and other FOSS licenses is all about
- FOSS = Collaboration
- FOSS = Engagement
- FOSS = Diverse groups working together
- FOSS = A process - a method. Build to implement an idea

But how does it actually work?
Let's find out!

How CentOS is NOT built

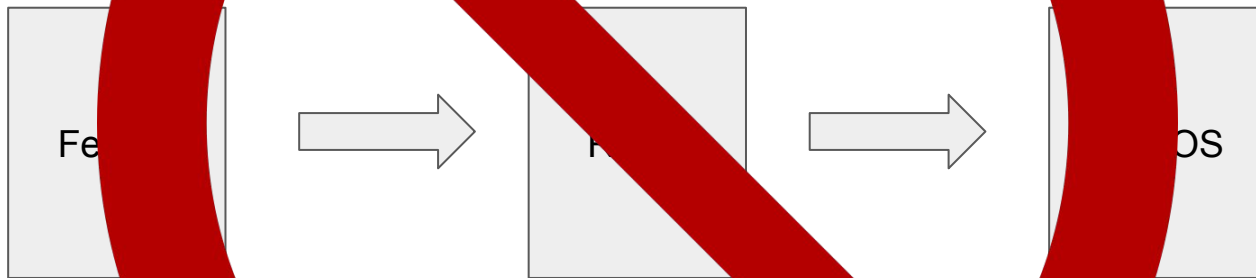

How is CentOS Linux related to RHEL?

- How the cookie used to crumble:
 - Git.centos.org sources
 - No SRPMS
 - Point in time different
 - Separate build systems - from compiler versions, compiler options and a lot more
 - Binaries very different

Upstream and Downstream - how it used to be

Upstream

Projects

kernel

cockpit

firefox

...

- 100,000+ projects in the Linux distro world
 - Majority of which are in RHEL/Fedora/EPEL
- Each project has its own life-cycle
 - Patch process
 - Issue management
 - PR process / rules
 - Ownership - some (a lot!) are owned by just one person
- Projects used by many distributions
 - Each distro may require conflicting changes
- Distro Package Managers are in charge of custom changes required by them
- Community involvement varies greatly

Upstream and Downstream - how it used to be

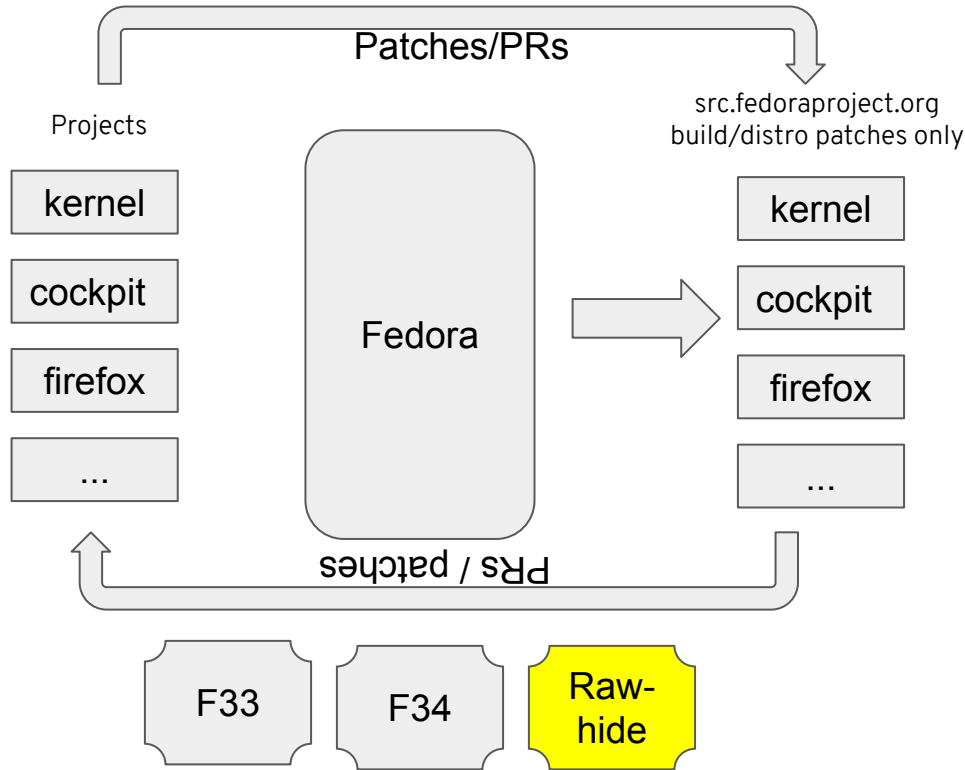

FEDORA

- Simplified Visual
- Fedora's git is all about building - not the actual upstream (tar)
- Lots of internal systems to manage flow to/from Fedora and upstream
- Upstream determines features, what/how to fix issues etc
- Complex process before the package makes it into a public repository

Upstream and Downstream - how it used to be

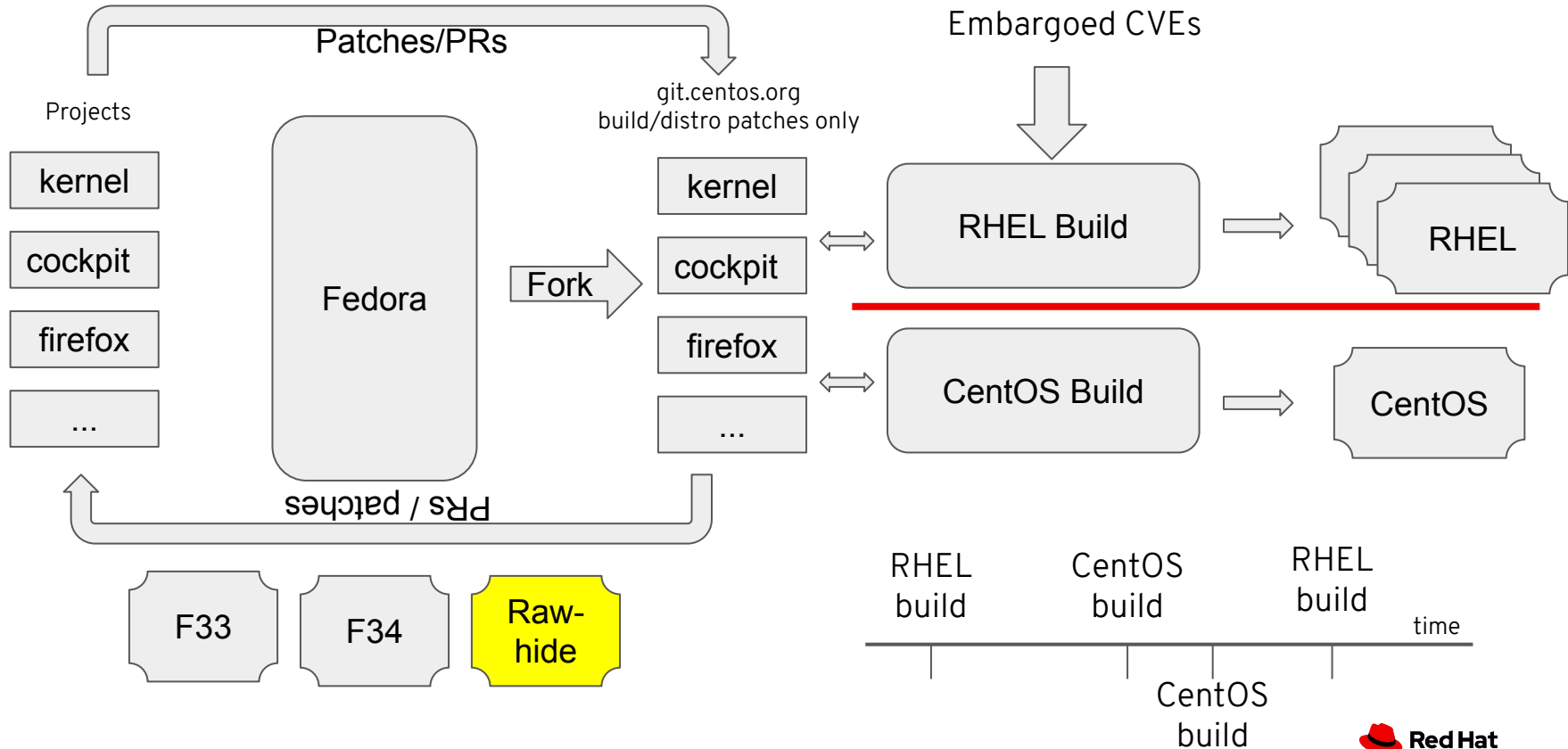

You were (are) not getting a free version of RHEL

- Sorry, but that's never been the case
- CentOS and RHEL uses different and independent build systems, versions of build tools, QA tools etc.
- CentOS and RHEL builds at different times
 - As 50000+ upstream projects have many changes a day, patches are created daily, the builds start from different points in time
- Typical binaries would differ between RHEL and CentOS more than 75% of the time
 - Different optimizations
 - Different patches included
- The RHEL QA does in other words not invoke CentOS's configuration
- Result: Hard if not impossible to use CentOS as a development platform if your target is RHEL certification



A brief pause to let
the shock sink in

BREATHHE!

CHEERS!



Let's calm the nerves and continue

In the beginning, FOSS created FEDORA

Some slides borrowed from Matthew Miller



What is Fedora?

The Fedora Project is a community of people working together to build a free and open source software platform and to collaborate on and share user-focused solutions built on that platform.

Or, in plain English, we make an operating system and we make it easy for you do useful stuff with it.

What is Fedora all about?

The Fedora community includes thousands of individuals with different views and approaches, but together we share some common values.

We call these the “**Four Foundations**”: Freedom, Friends, Features, and First.

Fedora on the Innovation Curve

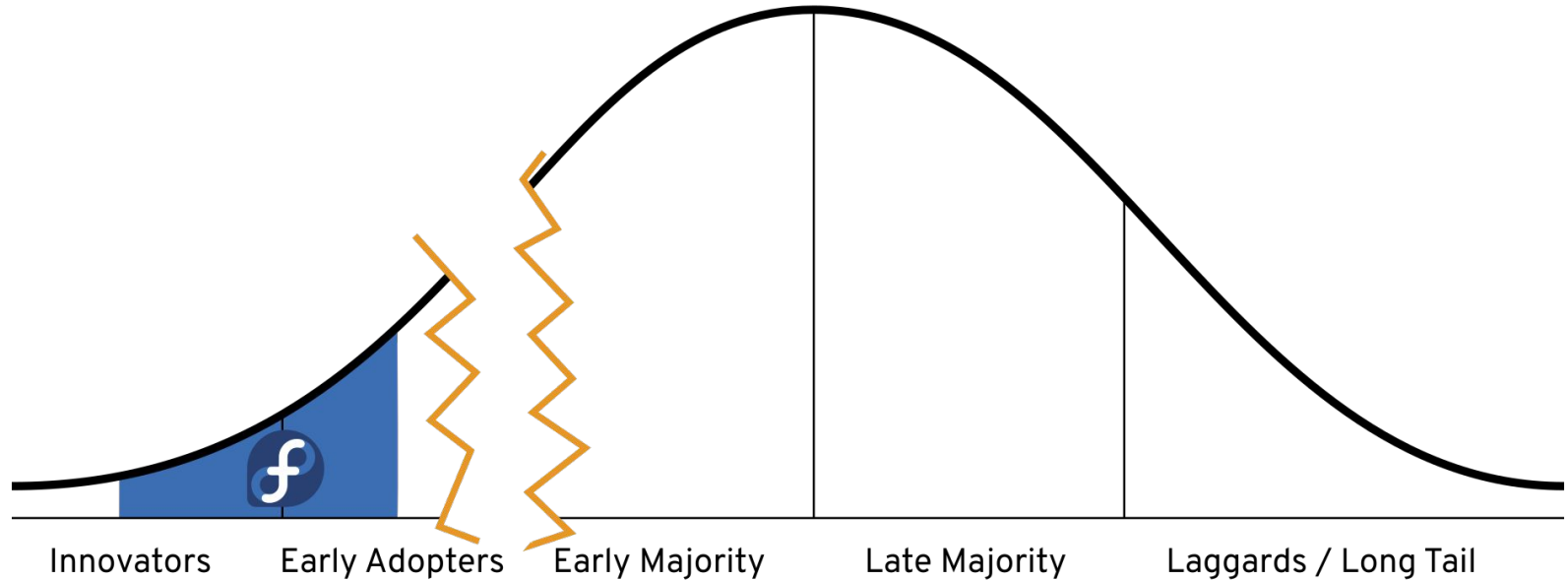

Our Mission

Fedora creates an innovative platform for hardware, clouds, and containers that enables software developers and community members to build tailored solutions for their users.

Or, the Plain Language Version

We make an OS, and we make it easy for you to do useful stuff with it.

We're particularly interested in helping our community build things for users.

Does everyone work for Red Hat?

Contributors with the top bodhi, dist-git, and wiki activity in 2015

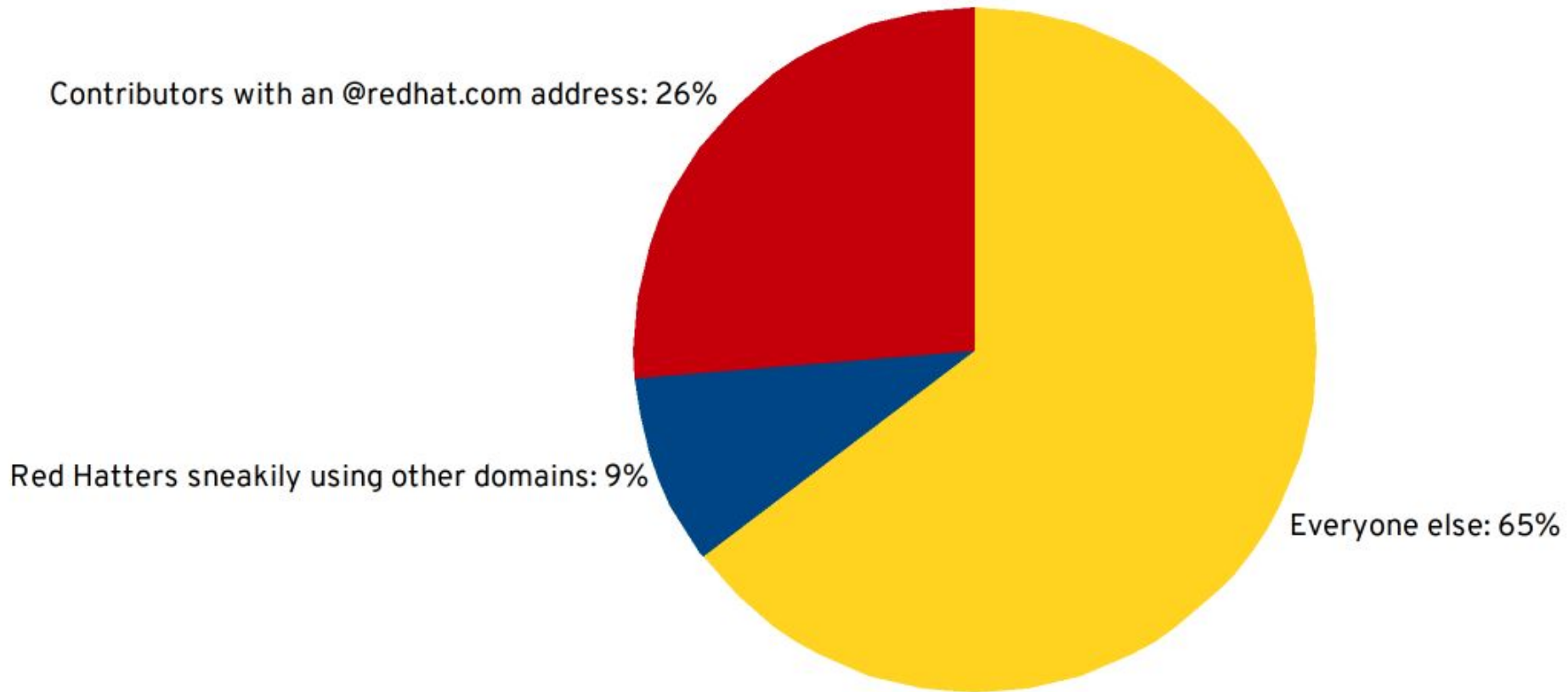

Community Governance

Red Hatters don't get special privileges in Fedora. Access needs to be earned on an individual basis.

Strategic decisions are made by the Fedora Council and engineering ones by individual teams or the Fedora Engineering Steering Committee (FESCo).

A Rough Map of Fedora

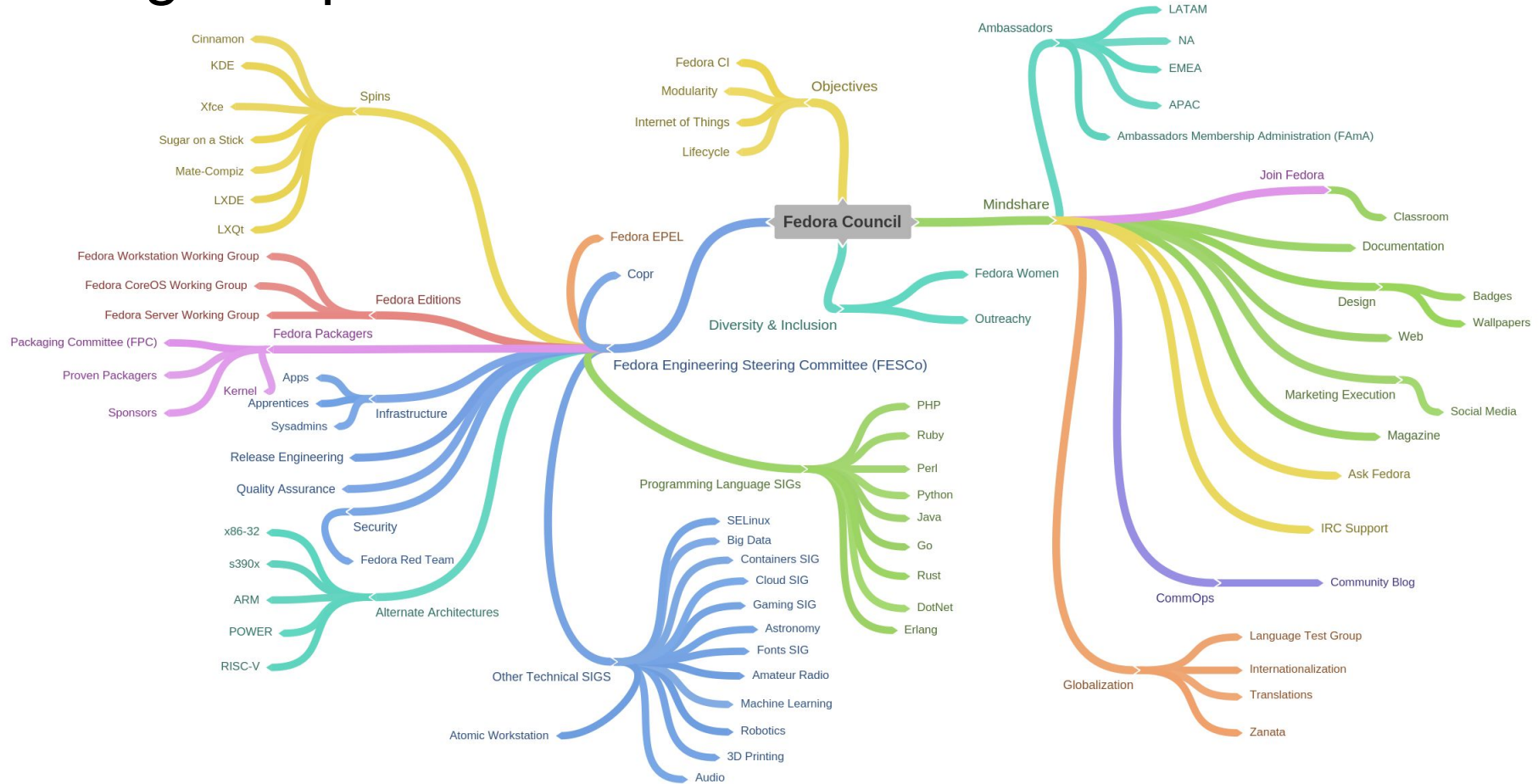

A quick census...

The Fedora Packagers group has 2427 members.

On average, 207 different people made package changes every week in 2020.

Over the year, that's 931 of the 2427.

252 people are “Proven Packagers” with the ability to make bulk changes

Number of Contributors Making Changes to Packages Each Week

Grouped by Quarterly Activity Level of Each Contributor

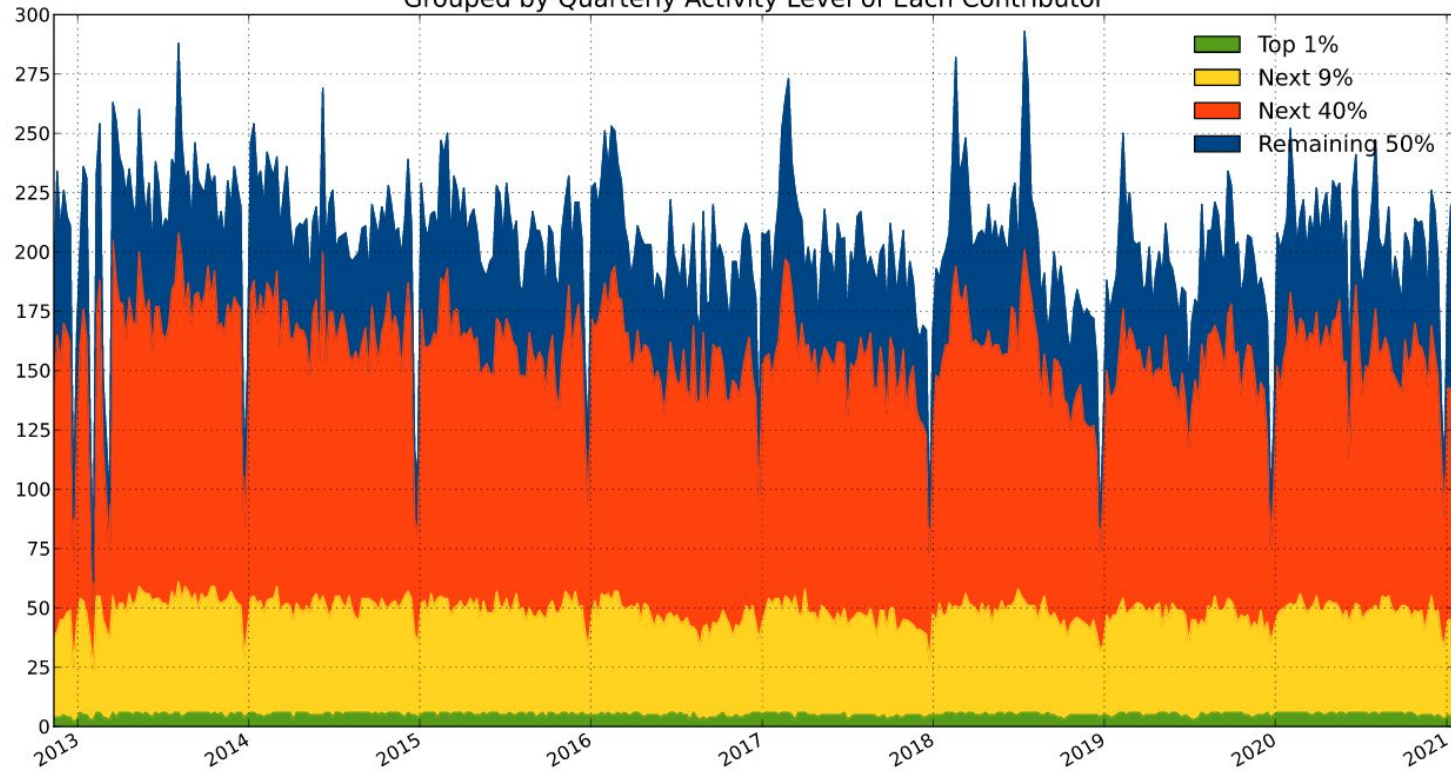

Getting a package into Fedora

- upstream
- create RPM
- bugzilla review
- dist-git
- fedpkg build
- koji
- bodhi
- released!

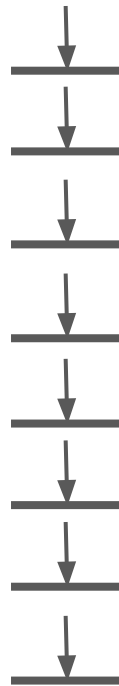

And now I can ``dnf install`` my package

... and so can other people, of course.

```
explorer1:~$ sudo dnf install dateutils
Place your finger on the fingerprint reader
Last metadata expiration check: 4:51:00 ago on Mon 18 Jan 2021 11:22:19 AM EST.
Dependencies resolved.
=====
Package                Architecture          Version                Repository             Size
=====
Installing:
dateutils              x86_64                0.4.7-3.fc33          fedora                 347 k
=====
Transaction Summary
=====
Install 1 Package

Total download size: 347 k
Installed size: 1.2 M
Is this ok [y/N]: y
Downloading Packages:
dateutils-0.4.7-3.fc33.x86_64.rpm                                1.3 MB/s | 347 kB    00:00
-----
Total                                                            742 kB/s | 347 kB    00:00
Running transaction check
Transaction check succeeded.
Running transaction test
Transaction test succeeded.
Running transaction
  Preparing      :
  Installing     : dateutils-0.4.7-3.fc33.x86_64                1/1
  Running scriptlet: dateutils-0.4.7-3.fc33.x86_64                1/1
  Verifying      : dateutils-0.4.7-3.fc33.x86_64                1/1

Installed:
  dateutils-0.4.7-3.fc33.x86_64

Complete!
explorer1:~$ datediff 1993-03-26 now
10160
explorer1:~$
```

Not just Fedora OS users

EPEL, “Extra Packages for Enterprise Linux” is a key part of our project and uses the same package set but built to run on RHEL or CentOS Stream.

Fedora OS and EPEL Mirror Stats

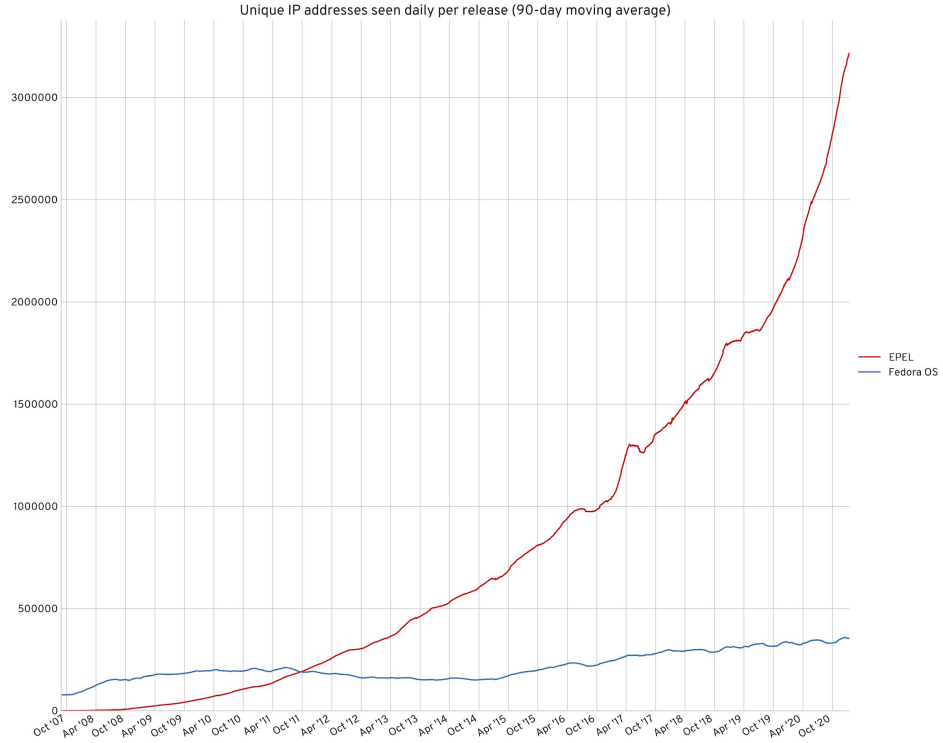

Links!

Download Brochure: <https://getfedora.org/>

Community Wiki: <https://fedoraproject.org/wiki/>

Documentation: <https://docs.fedoraproject.org/>

Discussion Forum: <https://discussion.fedoraproject.org/>

User Questions: <https://ask.fedoraproject.org/>

The journey to RHEL

Some slides borrowed from Aleksandra Fedorova

Before

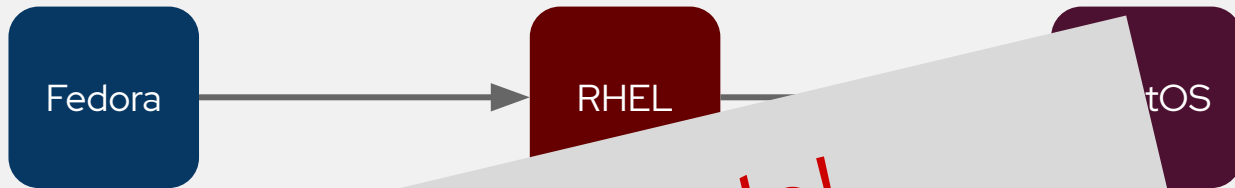

It is not that simple!

After



RHEL is not a box, it is a **line**

Question of time

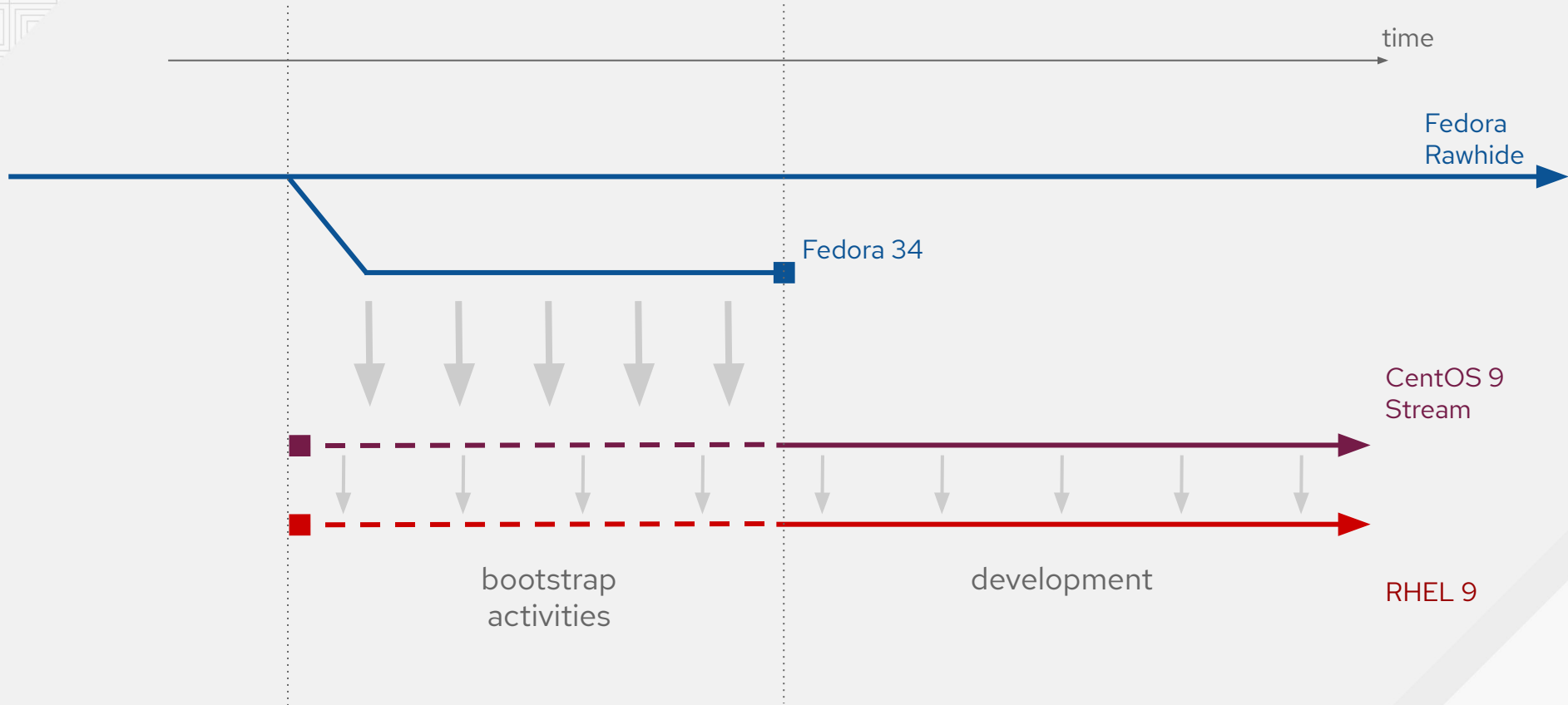

Only Fedora is eternal

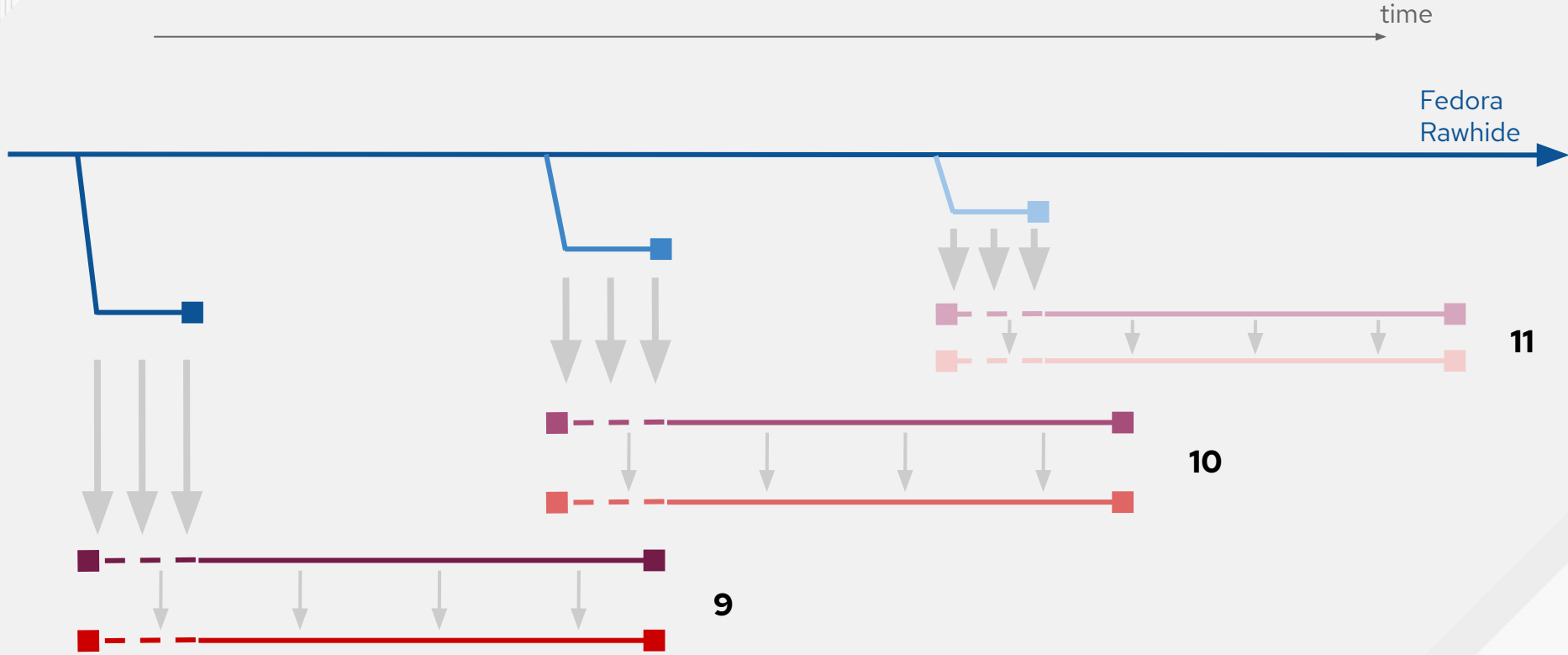

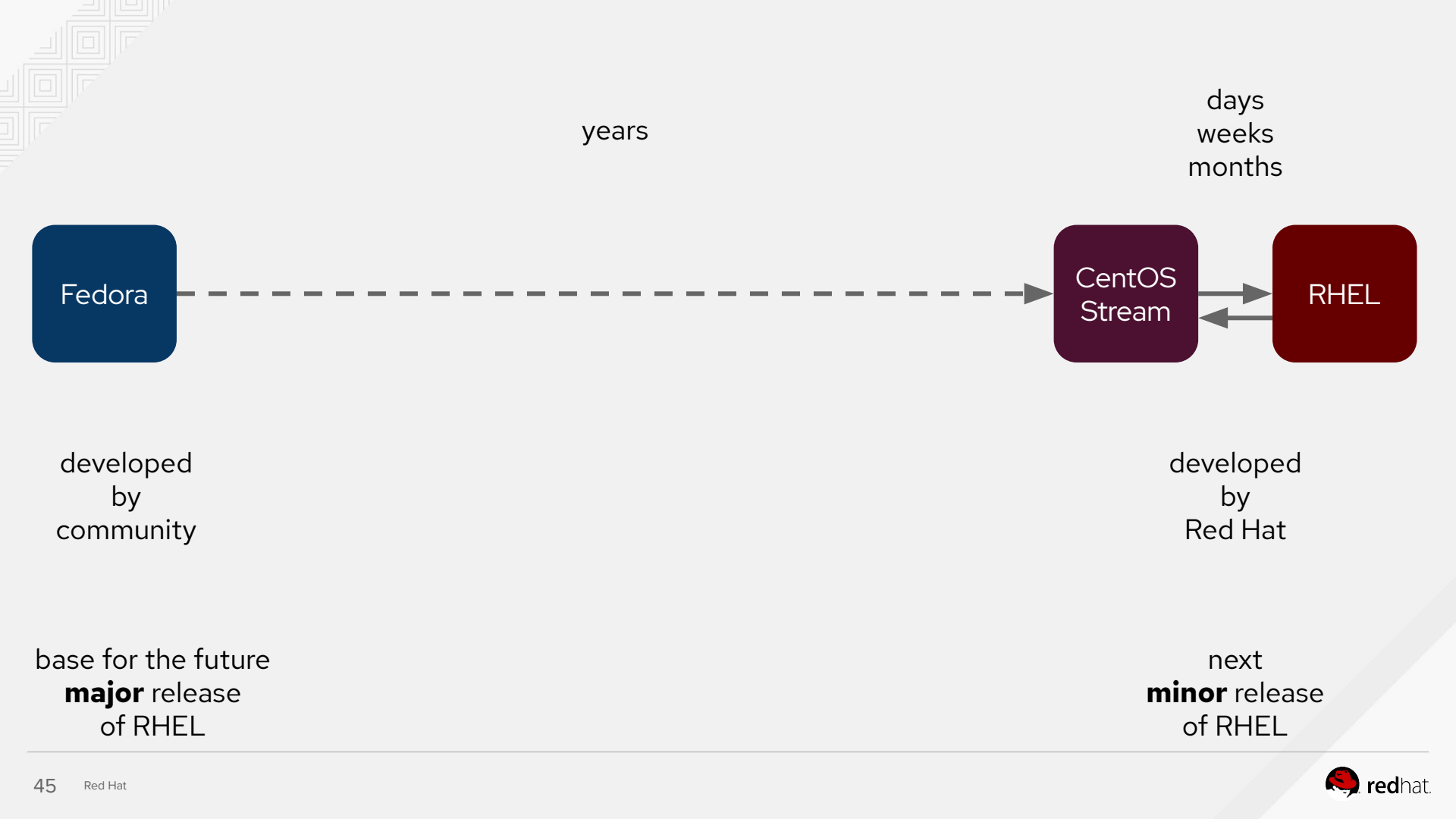

RHEL and CentOS Stream: who goes first?

Contribution by package



Contribution in sync on a package level

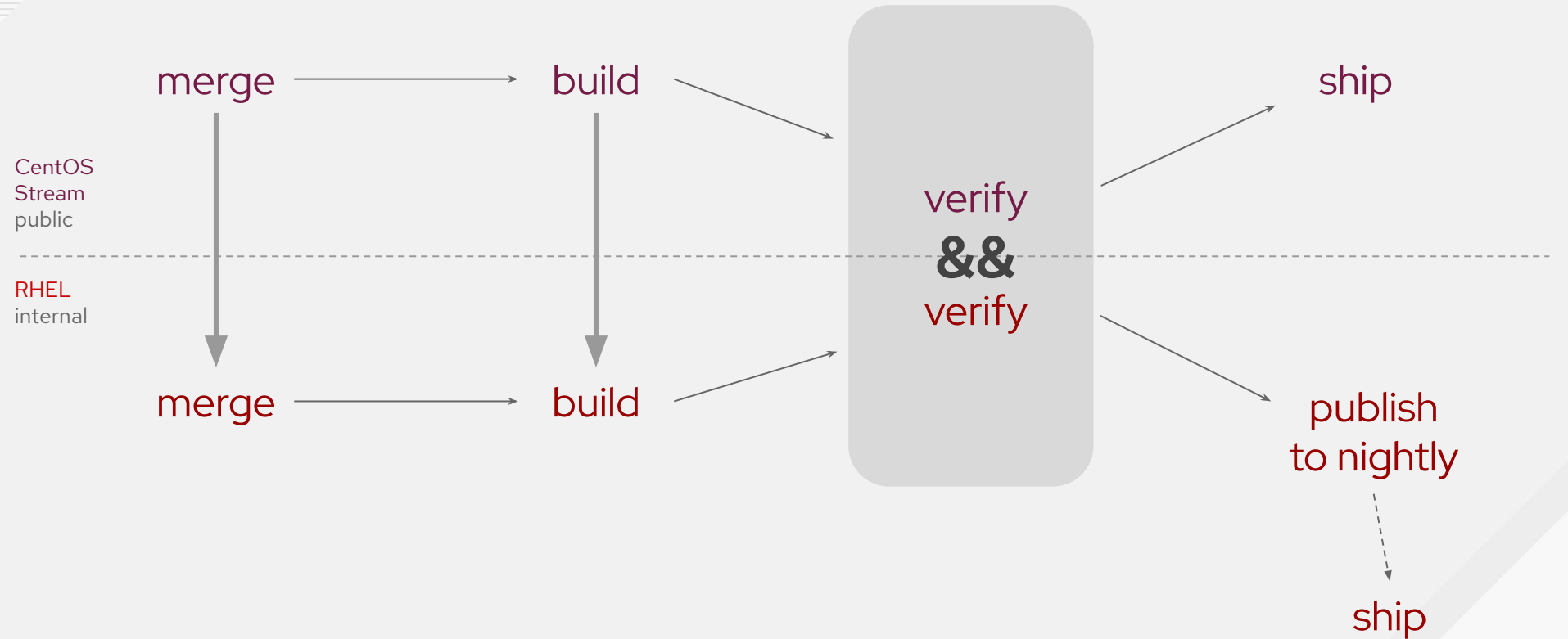

The Process being aimed at

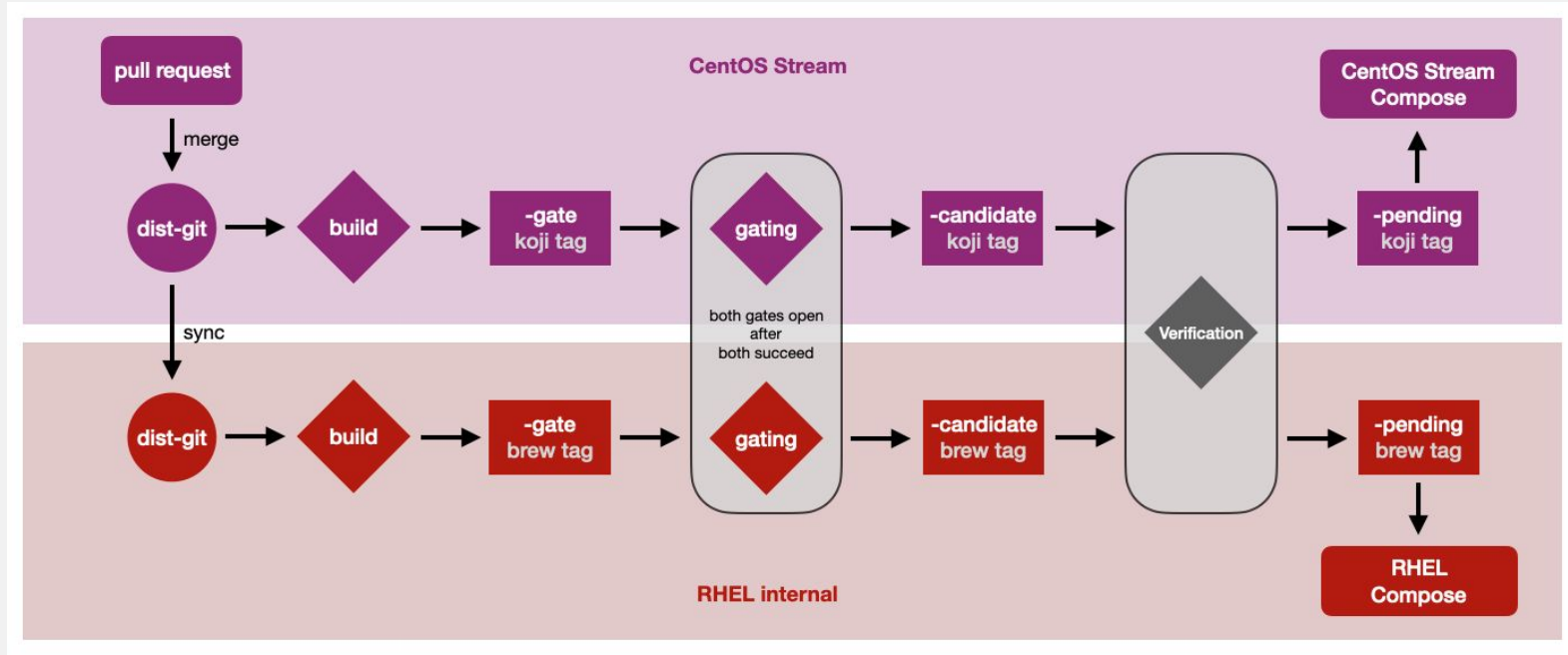

minor release

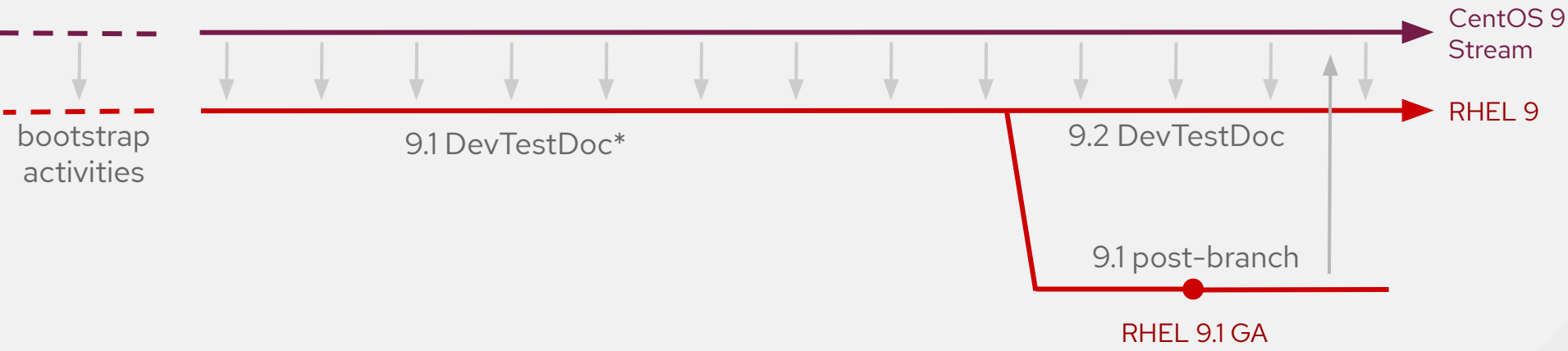

* **Development Testing Documentation**

Different from Fedora

- All package maintainers are from RHEL Engineering
- RHEL Engineering makes decisions which contributions to accept
 - By technical merit but also with guidance from the RHEL BU
- Verification is done by RHEL Developers and QE

- CentOS Stream contribution is a RHEL contribution and follows RHEL development policies
- Community can participate by sending patches, testing and via development of various ecosystem initiatives (EPEL, CentOS Plus, CentOS SIGs)

- CVE fixes are going to be published to RHEL first

How to test

The Gate



<https://www.flickr.com/photos/dgmckelvey/6935089322> (CC BY 2.0)

Tests via multiple CI systems

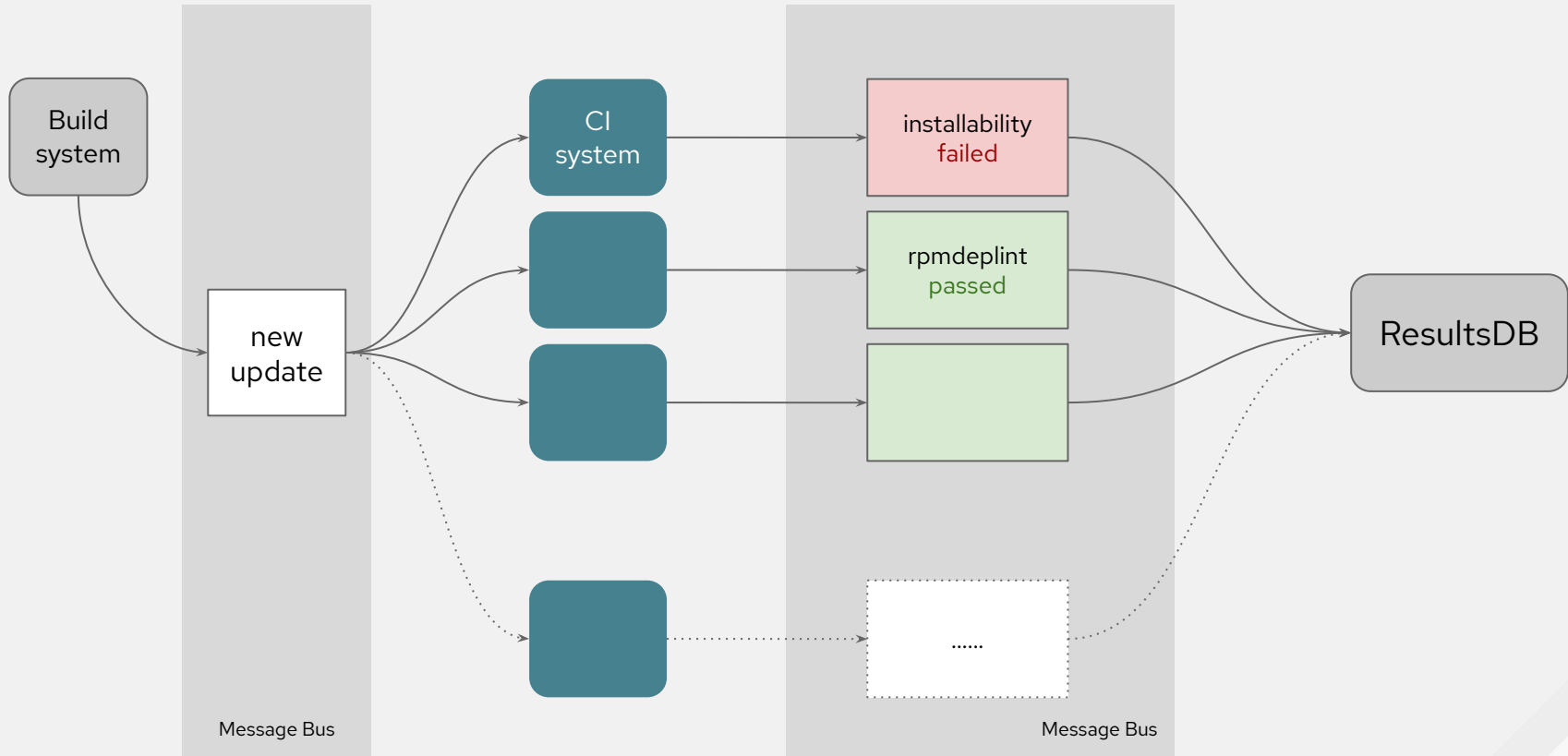

Test triggers and test results

- Build system sends a **New update is coming** message
- CI systems subscribe to Message Bus and listen to such messages
- Each CI system decides on its own how to handle the new update event
 - One CI system may react to updates of one particular package
 - Another may test all updates with a generic test
- When CI system processes the event, CI system sends the **test completed** message back to the Message Bus
- All **test completed** messages are aggregated in the ResultsDB

All Fedora and CentOS Stream messages are public.

https://apps.fedoraproject.org/datagrepper/raw?rows_per_page=1&delta=127800

<https://fedora-messaging.readthedocs.io/en/latest/#user-guide>

Test triggers and test results

ResultsDB stores all test results available for the update.

As soon as all *required* tests pass, the update is pushed through the gate.

Package owners can decide which tests are required for their packages.

How do **you** test the CentOS Stream?

- All messaging is public
- Subscribe to messages, and start processing them
 - For example, trigger tests somewhere on your custom hardware lab
- Send message with the result back to the public message bus
- Talk to a package maintainer to make your test blocking for that package

You can test Fedora the same way too!

[How to test Fedora updates with your custom CI](#)

Internet asks

- Is CentOS Stream a rolling release?
 - Not really.
CentOS Stream “rolls” only within the limits of one major release of RHEL and only until the end of the full support.
- Is CentOS Stream binary compatible with RHEL?
 - Yes.
Even better than CentOS Linux. As RHEL packages are built in the same order and at the same time as CentOS Stream packages.
- Is CentOS 9 Stream a beta-testing of RHEL?
 - Depends on the meaning of “beta-testing”.
RHEL 9 Beta is a different thing, which happens in the beginning of the new major version of RHEL. CentOS Stream can help test RHEL updates, but it is developed continuously in sync with RHEL updates, long after RHEL 9 Beta is released.

Thank you

Take away:

- CentOS Stream is closer to RHEL than CentOS Linux was
- Any update to CentOS and RHEL goes through a lot of gates/checks
- RHEL benefits from better access by ISVs and hardware partners
- CentOS benefits by becoming a true community where members have real influence

- Peter Larsen
Staff Domain Architect, NAPS
plarsen@redhat.com - Twitter: @egoalter

Backup Slides

Freedom



We are dedicated to free software and content.

Advancing software and content freedom is a central community goal, which we accomplish through the software and content we promote. We choose free alternatives to proprietary code and content and limit the effects of proprietary or patent encumbered code on the Project.

Friends



We are dedicated to free software and content.

Advancing software and content freedom is a central community goal, which we accomplish through the software and content we promote. We choose free alternatives to proprietary code and content and limit the effects of proprietary or patent encumbered code on the Project.

Features



We care about excellent software.

The Fedora community creates many of the technical features that have made Linux powerful, flexible, and usable for a wide spectrum of millions of users, administrators, and developers worldwide. We recognize the status quo is worth changing to empower additional end-users, or to create a more flexible and powerful environment for building new solutions on the free software we provide.

First



We are committed to innovation.

We are not content to let others do all the heavy lifting on our behalf; we provide the latest in stable and robust, useful, and powerful free software in our Fedora distribution.

At any point in time, the latest Fedora platform shows the future direction of the operating system as it is experienced by everyone from the home desktop user to the enterprise business customer.

Upstream: where it starts!

Fedora's primary activity is integration: making open source software work nicely together in our package collection. That, of course, starts with an upstream project.

The true project - upstream

- Upstream is the producer of the code, features and abilities
- Upstream supports multiple distributions
- Upstream project handles most bug fixes
- Upstream sets their own, independent release goals, features etc
- Has their own:
 - Bug reporting
 - Patching
 - Documentation
 - Community out-reach, groups, forums etc
- Problem: Lots of upstream projects are very small groups if not just one person

Dateutils

Dateutils are a bunch of tools that revolve around fiddling with dates and times in the command line with a strong focus on use cases that arise when dealing with large amounts of financial data.

Dateutils are hosted primarily on github:

- project homepage: <http://www.fresse.org/dateutils/>
- github page: <https://github.com/hroptatyr/dateutils>
- downloads: <https://bitbucket.org/hroptatyr/dateutils/downloads>

Below is a short list of examples that demonstrate what dateutils can do, for full specs refer to the info and man pages. For installation instructions refer to the INSTALL file.

Dateutils commands are prefixed with a `date` but otherwise resemble known unix commands for reasons of intuition. The only exception being `strptime` which is analogous to the libc function of the same name.

- `strptime` Command line version of the C function
- `dateadd` Add durations to dates or times
- `dateconv` Convert dates or times between calendars
- `datediff` Compute durations between dates or times
- `dategrep` Grep dates or times in input streams
- `dateround` Round dates or times to "fuller" values
- `dateseq` Generate sequences of dates or times

Languages

C	61%
shell script	27%
Autoconf	6%
4 Other	6%

more at [Open Hub](#)

dateutils Updated Jan 18, 2021

version **2.2.7**
licence **BSD3c**

[github page](#)
[latest release \(dateutils-0.4.7.tar.xz\)](#)
[latest snapshot](#)

Bugzilla: tracking packaging issues

Fedora uses Red Hat's Bugzilla instance at

<https://bugzilla.redhat.com>

Again, we're an integrator, so this is primarily for bugs in our packaging – code bugs go upstream.

(Mostly...)

Anyway, starts with review. Or, if a package is “in” already, perhaps a bug or simply a note that there's a new version.

**Bug 1198342 - Review Request: dateutils - Command-line date and time calculation, conversion, and comparison** ([edit](#))[Save Changes](#)This is a minor update (do not send email) Keywords: Status: CLOSED ERRATA ([edit](#))Product: Fedora   Component: Package Review  

Version: rawhide

Priority: medium

Severity: medium

Target Milestone: ---



Assignee: Christopher Meng ([edit](#)) ([take](#))

Pool: None

Reported: 2015-03-03 20:25 UTC by **Matthew Miller**CC List: Add me to CC list
5 users ([edit](#))Fixed In Version: Flags: zbysek: fedora-review gwync: fedora-cvs [\(more flags\)](#)

the bug is restricted to at least one group.

Matthew Miller 2015-03-03 20:25:40 UTC

Description Private    

[Collapse All Comments](#)

[Expand All Comments](#)

Spec URL: <http://mattdm.org/misc/fedora/dateutils.spec>

SRPM URL: <http://mattdm.org/misc/fedora/dateutils-0.3.1-1.fc21.mattdm.src.rpm>





Description:

[Add Comment](#)

Tools which revolve around fiddling with dates and times on the command line, with a strong focus on use cases that arise when dealing with large amounts of financial data.

Fedora Account System Username: mattdm

Christopher Meng 2015-03-03 23:33:28 UTC

Comment 1 Private    

Interesting, a guy just asked me 7 hours ago about packaging it...

I will review it.





Status: NEW → ASSIGNED

CC: i@cicku.me

Assignee: nobody@fedoraproject.org → i@cicku.me

Flags: fedora-review?

Christopher Meng 2015-03-04 12:39:54 UTC

Comment 2 Private    

Status: NEW → ASSIGNED

CC: i@cicku.me

Assignee: nobody@fedoraproject.org → i@cicku.me

Flags: fedora-review?

Christopher Meng 2015-03-04 12:39:54 UTC

Comment 2

Private



=====
Manual Review
=====

1. %check section is needed for

```
make check
```

2. Disable silent build by passing `--disable-silent-rules` to `%configure`, then you will see trouble 4.

3. Consider packaging octave binding(*optional*, as I don't find it useful so far, might not for others I think).

4. CFLAGS are being overridden by `march=native`(aarch64 doesn't support it) and even others, this is not good, please patch.

5. These program names are too common, please consider passing `--program-prefix='dateutils.'`, as it even conflicts with RHEL `dateutils` package(It's not in Fedora I checked).

Rüdiger Meier 2015-03-04 15:03:56 UTC

Comment 3

Private



About point 4 you could wait for `dateutils-0.3.2`, should be released today.

CC: sweet_f_a@gmx.de

Matthew Miller 2015-03-04 17:21:35 UTC

Comment 4

Private



dist-git: where our build rules live

Just normal git, but used differently:

1. Holds spec files and patches, not upstream code
2. Tar archives of that code stored in a look-aside cache

(Coming soon: source-git.)



rpms / dateutils

[Open PR](#)
[Fork](#)
[Clone](#)

- [Source](#)
[Issues](#)
[Pull Requests](#)
[Stats](#)
[Settings](#)

rpms / dateutils

Created 3 years ago
Maintained by mattdm

Tools which revolve around fiddling with dates and times on the command line, with a strong focus on use cases that arise when dealing with large amounts of financial data. (upstream)

[Star](#) 0
 [Unwatch](#) 2
 [Members](#) 2

[Builds Status](#)
[Updates Status](#)
[Bug Reports](#)
[Packages](#)
[Koschei Status](#)

Overview

Files

Commits

Branches

Forks

Releases

Monitoring status:

Scratch builds

Orphaned:

Orphan

Bugzilla Assignee:

Fedora:
mattdm

Release	Stable version	Version in testing
Fedora 34		
Fedora 33	dateutils-0.4.7-2.fc33	
Fedora 32	dateutils-0.4.6-3.fc32	

Overview

Files

Commits

Branches

Forks

Releases

Monitoring status:

Scratch builds

Orphaned:

Orphan

Bugzilla Assignee:

Fedora:
mattdm

EPEL:
mattdm

Edit

Files

Branch: master

master

.gitignore

6813ed94534f2311f9e9164748919e39d60b0190.patch

README.md

dateutils.spec

sources

README.md

Dateutils are hosted primarily on github:

- project homepage: <http://www.fresse.org/dateutils/>
- github page: <https://github.com/hroptatyr/dateutils>
- downloads: <https://bitbucket.org/hroptatyr/dateutils/downloads>

Branches

Forks

Releases

Monitoring status:

Scratch builds ▾

Orphaned:

Orphan

Bugzilla Assignee:

Fedora:
mattdm

EPEL:
mattdm

Edit

```
1 Name: dateutils
2 Version: 0.4.7
3 Release: 3%{?dist}
4 Summary: Command-line date and time calculation, conversion, and comparison
5
6 License: BSD
7 URL: http://www.fresse.org/dateutils/
8 Source0: https://github.com/hroptatyr/dateutils/releases/download/v%{version}/%{name}-%{version}.tar.xz
9
10 # Upstream fix for include issue. https://github.com/hroptatyr/dateutils/issues/109
11 Patch0: https://github.com/hroptatyr/dateutils/commit/6813ed94534f2311f9e9164748919e39d60b0190.patch
12
13 Requires(post): info
14 Requires(preun): info
15
16 BuildRequires: gcc
17 BuildRequires: make
18
19 %description
20 Tools which revolve around fiddling with dates and times on the command
21 line, with a strong focus on use cases that arise when dealing with large
22 amounts of financial data.
23
24
25 %prep
26 %autosetup -p1
27
28
29 %build
30 %configure --disable-silent-rules --without-old-links
31 # see note in configure script for why we're passing CFLAGS explicitly here
```

fedpkg: command-line magic

We've got a command-line tool which pulls a lot of our systems together and gives an easy interface to them all.

``fedpkg clone`` pulls a particular package from dist-git

``fedpkg mockbuild`` does a local testing build

``fedpkg build`` makes an official build in our build system

``man fedpkg`` for a lot more



matt@m@explorer1:~/fedora/dateutils — /usr/bin/python3 /usr/bin/fedpkg scratch-build



```
explorer1:~/fedora/dateutils$ fedpkg scratch-build
Building dateutils-0.4.7-3.fc34 for rawhide
Created task: 59988635
Task info: https://koji.fedoraproject.org/koji/taskinfo?taskID=59988635
Watching tasks (this may be safely interrupted)...
59988635 build (rawhide, /rpms/dateutils.git:ecb95b0623eb7066abec9d63ae7f1a86cf7c5e54): free
```

Koji: where builds actually happen

You can't just build a package on your laptop and upload it to Fedora. It has to be built in the build system from dist-git.

Information for task [build \(rawhide, /rpms/dateutils.git:ecb95b0623eb7066abec9d63ae7f1a86cf7c5e54\)](#)

ID	59988635
Method	build
Parameters	Source: git+https://src.fedoraproject.org/rpms/dateutils.git#ecb95b0623eb7066abec9d63ae7f1a86cf7c5e54 Build Target: rawhide Options: scratch = True
State	open
Created	Mon, 18 Jan 2021 21:05:14 UTC
Started	Mon, 18 Jan 2021 21:05:26 UTC
Total time	0:00:55
Task time	0:00:43
Owner	mattDM
Channel	default
Host	buildvm-s390x-20.s390.fedoraproject.org
Arch	noarch
Parent	
Descendants	build └─ buildSRPMFromSCM (/rpms/dateutils.git:ecb95b0623eb7066abec9d63ae7f1a86cf7c5e54)
Waiting?	yes
Awaited?	no

Options:

scratch = True

State open**Created** Mon, 18 Jan 2021 21:05:14 UTC**Started** Mon, 18 Jan 2021 21:05:26 UTC**Total time** 0:02:39**Task time** 0:02:27**Owner** mattdm**Channel** default**Host** buildvm-s390x-20.s390.fedoraproject.org**Arch** noarch**Parent****Descendants** build

— buildSRPMFromSCM (/rpms/dateutils.git:ecb95b0623eb7066abec9d63ae7f1a86cf7c5e54)

— buildArch (dateutils-0.4.7-3.fc34.src.rpm, armv7hl)

— buildArch (dateutils-0.4.7-3.fc34.src.rpm, i686)

— buildArch (dateutils-0.4.7-3.fc34.src.rpm, x86_64)

— buildArch (dateutils-0.4.7-3.fc34.src.rpm, aarch64)

— buildArch (dateutils-0.4.7-3.fc34.src.rpm, ppc64le)

— buildArch (dateutils-0.4.7-3.fc34.src.rpm, s390x)

Waiting? yes**Awaited?** no**Priority** 20**Weight** 0.20**Result****Output**

```
sh-protection -fcf-protection -Wl,-z,relro -Wl,--as-needed -Wl,-z,now -specs=/usr/lib/rpm/redhat/redhat-hardened-ld -o dround dround-dround.o libdutio.a
../lib/libdudt.a
/bin/sh ../libtool --tag=CC --mode=link gcc -std=gnull -O2 -flto=auto -ffat-lto-objects -fexceptions -g -grecord-gcc-switches -pipe -Wall -Werror=format-
security -Wp,-D_FORTIFY_SOURCE=2 -Wp,-D_GLIBCXX_ASSERTIONS -specs=/usr/lib/rpm/redhat/redhat-hardened-cc1 -fstack-protector-strong -specs=/usr/lib/rpm/redhat
/redhat-annobin-cc1 -m64 -mtune=generic -fasynchronous-unwind-tables -fstack-clash-protection -fcf-protection -Wl,-z,relro -Wl,--as-needed -Wl,-z,now
-specs=/usr/lib/rpm/redhat/redhat-hardened-ld -o dseq dseq-dseq.o libdutio.a ../lib/libdudt.a
/bin/sh ../libtool --tag=CC --mode=link gcc -std=gnull -O2 -flto=auto -ffat-lto-objects -fexceptions -g -grecord-gcc-switches -pipe -Wall -Werror=format-
security -Wp,-D_FORTIFY_SOURCE=2 -Wp,-D_GLIBCXX_ASSERTIONS -specs=/usr/lib/rpm/redhat/redhat-hardened-cc1 -fstack-protector-strong -specs=/usr/lib/rpm/redhat
/redhat-annobin-cc1 -m64 -mtune=generic -fasynchronous-unwind-tables -fstack-clash-protection -fcf-protection -Wl,-z,relro -Wl,--as-needed -Wl,-z,now
-specs=/usr/lib/rpm/redhat/redhat-hardened-ld -o dsort dsort-dsort.o libdutio.a ../lib/libdudt.a
libtool: link: gcc -std=gnull -O2 -flto=auto -ffat-lto-objects -fexceptions -g -grecord-gcc-switches -pipe -Wall -Werror=format-security -Wp,-
D_FORTIFY_SOURCE=2 -Wp,-D_GLIBCXX_ASSERTIONS -specs=/usr/lib/rpm/redhat/redhat-hardened-cc1 -fstack-protector-strong -specs=/usr/lib/rpm/redhat/redhat-
annobin-cc1 -m64 -mtune=generic -fasynchronous-unwind-tables -fstack-clash-protection -fcf-protection -Wl,-z -Wl,relro -Wl,--as-needed -Wl,-z -Wl,now
-specs=/usr/lib/rpm/redhat/redhat-hardened-ld -o dconv dconv-dconv.o libdutio.a ../lib/libdudt.a
libtool: link: gcc -std=gnull -O2 -flto=auto -ffat-lto-objects -fexceptions -g -grecord-gcc-switches -pipe -Wall -Werror=format-security -Wp,-
D_FORTIFY_SOURCE=2 -Wp,-D_GLIBCXX_ASSERTIONS -specs=/usr/lib/rpm/redhat/redhat-hardened-cc1 -fstack-protector-strong -specs=/usr/lib/rpm/redhat/redhat-
annobin-cc1 -m64 -mtune=generic -fasynchronous-unwind-tables -fstack-clash-protection -fcf-protection -Wl,-z -Wl,relro -Wl,--as-needed -Wl,-z -Wl,now
-specs=/usr/lib/rpm/redhat/redhat-hardened-ld -o ddiff ddiff-ddiff.o libdutio.a ../lib/libdudt.a
libtool: link: gcc -std=gnull -O2 -flto=auto -ffat-lto-objects -fexceptions -g -grecord-gcc-switches -pipe -Wall -Werror=format-security -Wp,-
D_FORTIFY_SOURCE=2 -Wp,-D_GLIBCXX_ASSERTIONS -specs=/usr/lib/rpm/redhat/redhat-hardened-cc1 -fstack-protector-strong -specs=/usr/lib/rpm/redhat/redhat-
annobin-cc1 -m64 -mtune=generic -fasynchronous-unwind-tables -fstack-clash-protection -fcf-protection -Wl,-z -Wl,relro -Wl,--as-needed -Wl,-z -Wl,now
-specs=/usr/lib/rpm/redhat/redhat-hardened-ld -o dround dround-dround.o libdutio.a ../lib/libdudt.a
libtool: link: gcc -std=gnull -O2 -flto=auto -ffat-lto-objects -fexceptions -g -grecord-gcc-switches -pipe -Wall -Werror=format-security -Wp,-
D_FORTIFY_SOURCE=2 -Wp,-D_GLIBCXX_ASSERTIONS -specs=/usr/lib/rpm/redhat/redhat-hardened-cc1 -fstack-protector-strong -specs=/usr/lib/rpm/redhat/redhat-
annobin-cc1 -m64 -mtune=generic -fasynchronous-unwind-tables -fstack-clash-protection -fcf-protection -Wl,-z -Wl,relro -Wl,--as-needed -Wl,-z -Wl,now
-specs=/usr/lib/rpm/redhat/redhat-hardened-ld -o dsort dsort-dsort.o libdutio.a ../lib/libdudt.a
libtool: link: gcc -std=gnull -O2 -flto=auto -ffat-lto-objects -fexceptions -g -grecord-gcc-switches -pipe -Wall -Werror=format-security -Wp,-
D_FORTIFY_SOURCE=2 -Wp,-D_GLIBCXX_ASSERTIONS -specs=/usr/lib/rpm/redhat/redhat-hardened-cc1 -fstack-protector-strong -specs=/usr/lib/rpm/redhat/redhat-
annobin-cc1 -m64 -mtune=generic -fasynchronous-unwind-tables -fstack-clash-protection -fcf-protection -Wl,-z -Wl,relro -Wl,--as-needed -Wl,-z -Wl,now
-specs=/usr/lib/rpm/redhat/redhat-hardened-ld -o dseq dseq-dseq.o libdutio.a ../lib/libdudt.a
```

Method build

Parameters **Source:** [git+https://src.fedoraproject.org/rpms/dateutils.git#ecb95b0623eb7066abec9d63ae7f1a86cf7c5e54](https://src.fedoraproject.org/rpms/dateutils.git#ecb95b0623eb7066abec9d63ae7f1a86cf7c5e54)
Build Target: [rawhide](#)
Options:
scratch = True

State **closed**

Created Mon, 18 Jan 2021 21:05:14 UTC

Started Mon, 18 Jan 2021 21:05:26 UTC

Completed Mon, 18 Jan 2021 21:12:09 UTC

Total time 0:06:55

Task time 0:06:43

Owner [mattDM](#)

Channel [default](#)

Host [buildvm-s390x-20.s390.fedoraproject.org](#)

Arch noarch

Parent

Descendants **build**

- [buildSRPMFromSCM \(/rpms/dateutils.git:ecb95b0623eb7066abec9d63ae7f1a86cf7c5e54\)](#)
- [buildArch \(dateutils-0.4.7-3.fc34.src.rpm, armv7hl\)](#)
- [buildArch \(dateutils-0.4.7-3.fc34.src.rpm, i686\)](#)
- [buildArch \(dateutils-0.4.7-3.fc34.src.rpm, x86_64\)](#)
- [buildArch \(dateutils-0.4.7-3.fc34.src.rpm, aarch64\)](#)
- [buildArch \(dateutils-0.4.7-3.fc34.src.rpm, ppc64le\)](#)
- [buildArch \(dateutils-0.4.7-3.fc34.src.rpm, s390x\)](#)

Waiting? no

Awaited? no

Priority 20

Weight 0.20

Result

Bodhi: the gatekeeper

Once built, a package build isn't released until it goes through the Bodhi updates system.

- Automatic tests and (some) gating
- Time in `updates-testing` for manual user tests

There's a web interface and also a `fedpkg` command. Either way, packagers should provide a human-readable reason for the new build, and watch for feedback.

○ dateutils-0.4.7-2.fc33

 FEDORA-2020-749ff23bc2 created by [mattdm](#) 9 months ago for [Fedora 33](#)
stable

Details

 Builds 1

 Automated Tests 26

Automatic update for dateutils-0.4.7-2.fc33.

Changelog

- * Wed Apr 29 2020 Matthew Miller <mattdm@fedoraproject.org> - 0.4.7-2
 - pull in upstream patch for build issue
 - use autoseup macro to apply patches. fun new stuff for old packagers!
- * Wed Apr 29 2020 Matthew Miller <mattdm@fedoraproject.org> - 0.4.7-1
 - upstream 0.4.7 bugfix release

How to install

```
sudo dnf upgrade --advisory=FEDORA-2020-749ff23bc2
```

 This update was automatically created

9 months ago

 This update's test gating status has been changed to 'waiting'.

9 months ago

METADATA

Type	○ unspecified
Karma	 0
Signed	✔
Content Type	RPM

TEST GATING

✔ no tests are required

BUILDS 1

dateutils-0.4.7-2.fc33

SETTINGS

Unstable by Karma

 -3





Stable by Karma

disabled

Finally, it actually goes to the mirrors...

We have a volunteer-run network of mirrors all around the world, which is good because outgoing bandwidth from our datacenter is constantly saturated.

MirrorManager points clients at an appropriate close mirror.

 dataquay-devel-0.9.1-4.20190227gitb82360a98f49.fc33.i686.rpm	2020-07-28 05:13	39K
 dataquay-devel-0.9.1-4.20190227gitb82360a98f49.fc33.x86_64.rpm	2020-07-28 05:13	39K
 dataurl-0-0.3.20200110gitd1553a7.fc33.x86_64.rpm	2020-07-29 00:09	1.1M
 date-devel-3.0.0-3.20200708git6952fb5.fc33.i686.rpm	2020-08-01 00:53	47K
 date-devel-3.0.0-3.20200708git6952fb5.fc33.x86_64.rpm	2020-08-01 00:53	47K
 datefudge-1.23-2.fc33.x86_64.rpm	2020-07-28 05:15	22K
 dateutils-0.4.7-3.fc33.x86_64.rpm	2020-07-28 05:15	347K
 datovka-4.15.3-1.fc33.x86_64.rpm	2020-09-21 22:34	1.6M
 dav1d-0.7.1-2.fc33.x86_64.rpm	2020-07-28 05:15	30K
 davfs2-1.6.0-1.fc33.x86_64.rpm	2020-08-07 21:02	158K
 davix-0.7.6-3.fc33.x86_64.rpm	2020-08-02 08:35	648K
 davix-devel-0.7.6-3.fc33.i686.rpm	2020-08-02 08:35	35K
 davix-devel-0.7.6-3.fc33.x86_64.rpm	2020-08-02 08:35	35K
 davix-doc-0.7.6-3.fc33.noarch.rpm	2020-08-02 08:35	178K
 davix-libs-0.7.6-3.fc33.i686.rpm	2020-08-02 08:35	476K
 davix-libs-0.7.6-3.fc33.x86_64.rpm	2020-08-02 08:35	438K
 daxctl-69-2.fc33.x86_64.rpm	2020-07-28 18:43	47K
 daxctl-devel-69-2.fc33.i686.rpm	2020-07-28 18:43	19K
 daxctl-devel-69-2.fc33.x86_64.rpm	2020-07-28 18:43	19K
 daxctl-libs-69-2.fc33.i686.rpm	2020-07-28 18:43	39K
 daxctl-libs-69-2.fc33.x86_64.rpm	2020-07-28 18:43	38K
 daxio-1.9-4.fc33.x86_64.rpm	2020-08-18 19:34	94K
 dayjournal-23.0.6-10.fc33.x86_64.rpm	2020-07-28 05:17	105K